

GENERAL NOTES:

- SIDEWALK EXPANSION JOINTS AT 50' CENTERS MAX, TRANSVERSE JOINTS AT 5' CENTERS MAX.
- SUB-BASE SHALL BE MECHANICALLY COMPACTED
- PCC DRIVEWAY PAVEMENT SHALL BE NON-REINFORCED
- SIDEWALK ADA CURB RAMP AND DETECTABLE WARNINGS WHEN REQUIRED SHALL MEET STATE STANDARDS
- DETECTABLE WARNINGS SHALL BE REQUIRED AT STREET AND ALLEYWAY CROSSINGS
- DETECTABLE WARNING SHALL BE CAST-IN-PLACE WET-SET AND SHALL BE FEDERAL STANDARD COLOR 30166 (RED BRICK)

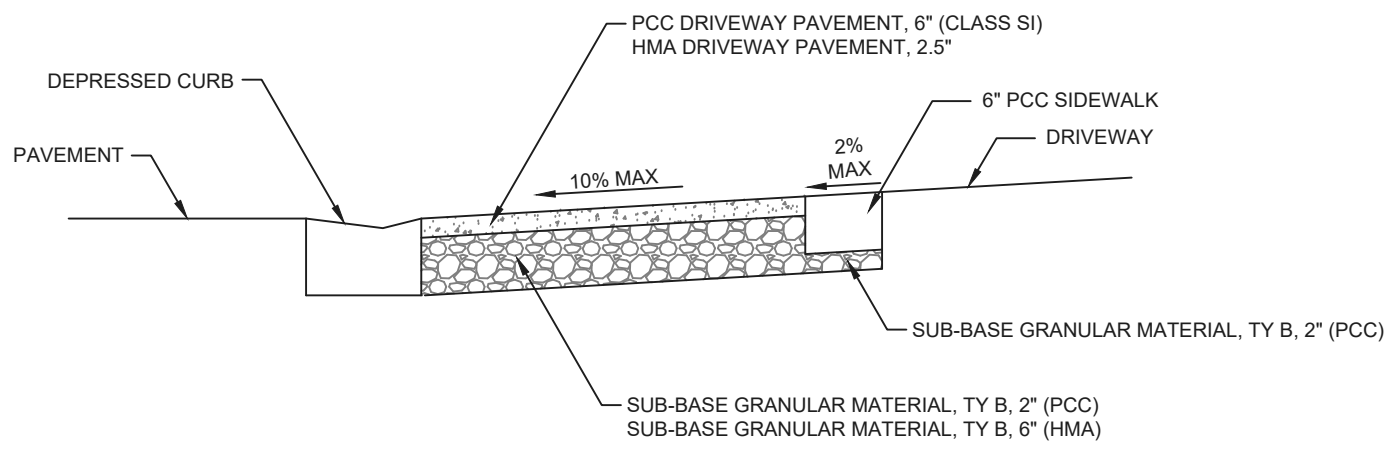

SECTION A-A

STANDARD RDY-007	
REVISIONS	