

GENERAL NOTES:

STEPS SHALL NOT BE ALLOWED IN THE VALVE VAULTS

CONCRETE ADJUSTING RINGS SHALL NOT EXCEED 12" IN HEIGHT AND SHALL HAVE MAXIMUM OF 3 RINGS, RUBBER MASTIC SHALL BE INSTALLED BETWEEN EACH JOINT

VALVE VAULT SHALL BE WATER TIGHT. EZ-STICK GASKET OR EQUAL SHALL BE INSTALLED AT ALL JOINTS. BOTTOM SECTION SHALL BE GROUTED WATER TIGHT WHEN PRE-CAST OR SPLIT BOTTOM SECTION IS PROPOSED

LUG HOLES SHALL BE FILLED WITH BITUMINOUS JOINING COMPOUND

RESTRAINING GLANDS ARE REQUIRED ON EACH SIDE OF THE VALVES WHEN STUBBED FOR FUTURE CONNECTION WITHIN TWO PIPE LENGTHS OF VALVE

STAINLESS STEEL VALVE STEM EXTENSION MAY BE REQUIRED IF STANDARD 8" VALVE KEY DOES NOT EXTEND 3' ABOVE FINISHED GROUND LEVEL. THE USE OF EXTENSIONS SHALL BE AT THE DISCRETION OF THE CITY.

VALVE, SIZE SPECIFIED
EPOXY COATED WITH
STAINLESS STEEL HARDWARE

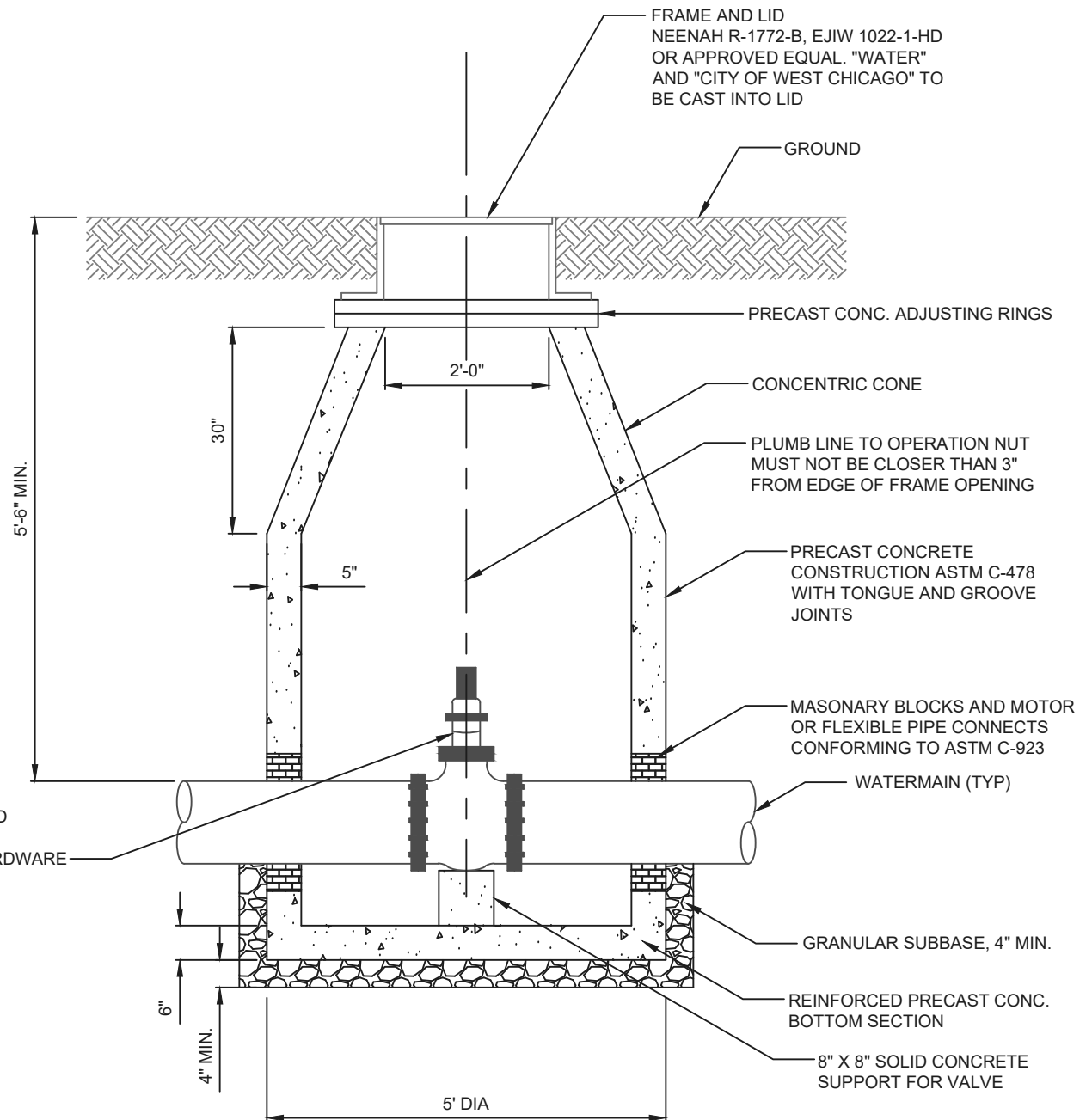

STANDARD WM-001



CITY OF WEST CHICAGO
475 MAIN STREET
WEST CHICAGO, IL 60185
PHONE: 630-293-2255
FAX: 630-293-2971

VALVE VAULT

CITY OF WEST CHICAGO
CONSTRUCTION SPECIFICATIONS,
STANDARDS, AND DETAILS

REVISIONS

NO.	DESCRIPTION