

**DOMESTIC RISER DIAGRAM
WITH FIRE SUPPRESSION**

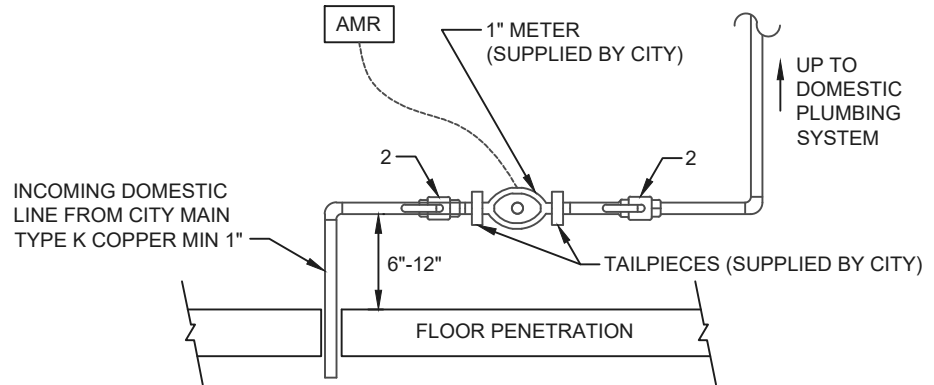

- 1 - BACKFLOW PREVENTOR
- 2 - BALL VALVE

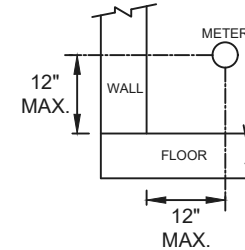
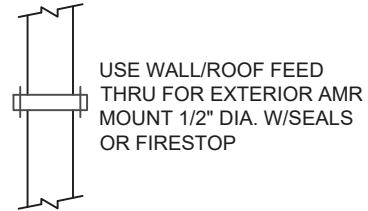

**DOMESTIC RISER DIAGRAM
WITHOUT FIRE SUPPRESSION**

GENERAL NOTES:

REFER TO NEPTUNE METER INSTALLATION INSTRUCTION FOR ADDITIONAL GENERAL AND INSTALLATION REQUIREMENTS.

ALL WATER METER BE INSTALLED HORIZONTALLY. VERTICAL INSTALLMENT SHALL BE PROHIBITED.

BONDING OF ELECTRICAL SYSTEM TO THE WATER METER SHALL NOT BE ALLOWED.

SPRINKLER METERS ARE TO BE INSTALLED AFTER MAIN METER TO RECEIVE METERING CREDIT.

STANDARD WM-008



CITY OF WEST CHICAGO
475 MAIN STREET
WEST CHICAGO, IL 60185
PHONE: 630-293-2255
FAX: 630-293-2971

RESIDENTIAL DOMESTIC RISER

CITY OF WEST CHICAGO
CONSTRUCTION SPECIFICATIONS,
STANDARDS, AND DETAILS

REVISIONS

NO.	DATE	DESCRIPTION